

# Places of worship

**HOWE**  
MOVING DESIGN  
SINCE 1928

# Sacred space

## Salisbury Cathedral

in the UK is a beautiful, historic building and a world-class heritage attraction. As the Cathedral is host to many different events, chairs often need to be moved, removed, and stacked. The design of the furniture, however, must respect the dignified environment of the cathedral. The 40/4 chair was chosen for its proven durability and simple design.

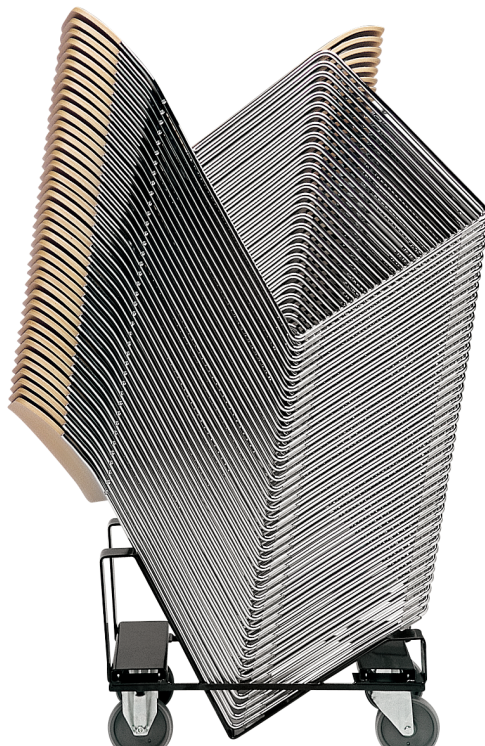



## Churches and places of worship

are intended for religious ceremonies and human contemplation. Today, though, they also often work as venues for concerts, seminars and other events. This calls for design that pays tribute to the timeless surroundings as well as offers the highest degree of flexibility. We like to believe that we deliver both – unequivocally.



## Flexibility

Flexible furniture solutions provide you optimal multi-usage of the holy space.



40/4 veneer side chairs  
DOM FORUM  
Cologne, Germany



40/4 veneer side chairs with custom engraved monogram  
CHAPELLE DES JÉSUITES  
Saint-Omer, France



# 40/4

Intelligent, purposeful,  
refined design

Don't be fooled by the simple and elegant design of the 40/4 chair by David Rowland.

The 40/4 chair has a light and airy aesthetic as well as superb seating comfort - the width of the seat is 490 mm / 19.3". Here we are dealing with a chair that is as strong in construction as it is simple in design.

The frame is made of a solid steel rod and the chair has been tested to both the ANSI/BIFMA X5.1 and the EN 16139:2013 standard for strength and durability.

This chair is meant for severe contract use!

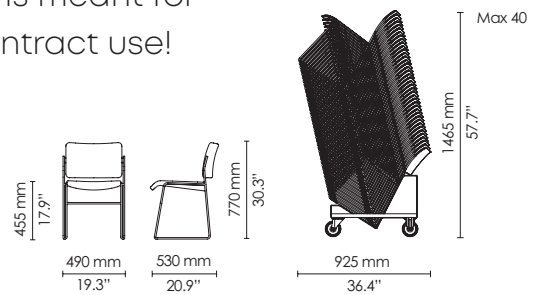

## Long-lasting durability

Our hard-wearing furniture solutions have a proven track record stretching back more than 45 years - they simply become companions.

2500 40/4 chairs by David Rowland at St. Paul's Cathedral in the UK have been used and moved each day since 1973 and are still in good condition.







40/4 veneer side chairs  
ST. PAUL'S CATHEDRAL  
London, UK

Places of worship



^ 40/4 side chairs + Tempest tables  
BIRKERØD SOGNEGÅRD  
Birkerød, Denmark

40/4 side chairs + Tempest tables v  
LIBERAAL JOODSE GEMEENTE  
AMSTERDAM  
Amsterdam, The Netherlands

## Enhancing architecture

Through timeless design, HOWE solutions strive to enhance the architecture, whether historical or modern.



40/4 side chairs  
ST. PETRI KAPELLE  
Brandenburg an der Havel, Germany

## Optimising space

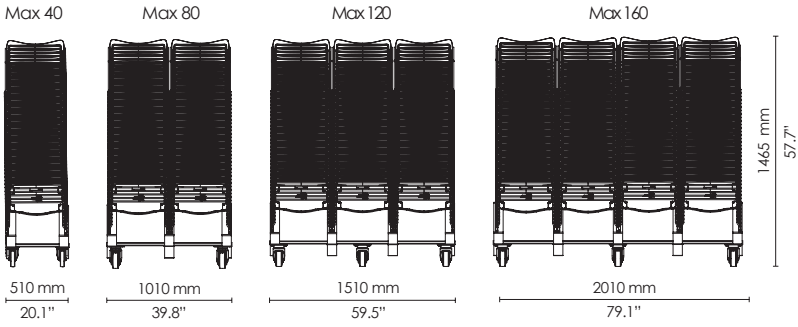

40 chairs on a single dolly take up only 0,47 m<sup>2</sup> / 5.1 ft<sup>2</sup> of floor space.

160 chairs on a quadruple dolly take up less than 2 m<sup>2</sup> / 21.5 ft<sup>2</sup> of floor space.





40/4 veneer side chairs  
CANTERBURY CATHEDRAL  
Canterbury, UK

Places of worship



^ 40/4 veneer side chairs  
PHILADELPHIA EPISCOPAL CATHEDRAL  
Philadelphia, USA

v 40/4 upholstered side chairs v  
EPIPHANIAS KIRCHE  
Germany



Photo: Lara Swimmer

40/4 upholstered side chairs  
UNITARIAN UNIVERSALIST FELLOWSHIP OF  
CENTRAL OREGON (UUFÇO)  
Oregon, USA



HOWE passionately creates  
Flexible furniture  
solutions  
that provide a haven for creative  
reflection and liberation of thoughts.

40/4 veneer side chairs  
CAERMERSKLOOSTER  
Gent, Belgium



# Moving Sustainability

At HOWE we believe that every good design must contribute to a more sustainable future. Because our world needs it more than ever.

The HOWE concept of Moving Sustainability is present in everything we do. As such, all HOWE chairs are FSC certified. The FSC stamp is your guarantee that all the wood used comes from sustainable forestry.



The mark of  
responsible forestry

40/4 wood frame  
side chairs



## Places of worship

### 40/4

Design by David Rowland



Side chair



Armchair



Wood frame



Barstool



Stacks 40 chairs



Stacks 25 chairs

### 40/4 accessories



Hymn book holder



Armchair linking

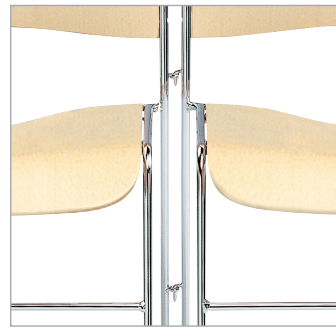

Hook-eye linking



Brace linking

## Tempest

Design by HOWE / Komplot Design



## Usu

Design by HOWE



Stacks 10 tables

# Places of worship

A selection of HOWE references:

## AUSTRALIA

Catholic Archdiocese of Sydney  
 Christian City Church  
 Resurrection Catholic Parish  
 Sidney Church  
 St. Barnabas Church  
 St. John's Cathedral  
 St. Mary's Chapter  
 St. Peter Julians Church  
 Woy Woy Church

## AUSTRIA

Dompfarre Graz  
 Klooster ZOMS  
 Vinomnasaal Rankweil

## BELGIUM

Caermersklooster  
 Gemeentebestuur Kapellen  
 Virgo Fidelis

## DENMARK

Adventskirken  
 Anna Church  
 Astrup Sognegaard  
 Birkerøed Sognegaard  
 Broedremenigheden  
 Engesvang Kirke  
 Evangeliekirken  
 Folkekirkens Hus  
 Gaarslev Menighedshus  
 Graesby Kirke  
 Graested menighedshus  
 Groendalskirken  
 Harboøre Kirke  
 Helligtrekongers Kirke  
 Hundige Church  
 Lemvig Kirke  
 Roskilde Domkirke  
 St. Nicolai Kirke  
 Skanderup Menighedshus  
 Saedden Kirke  
 Vojens Menighedshus

## FRANCE

Association Monsieur Vincent - Residence Ste Genevieve  
 Chapelle des Jésuites  
 Chapelle Oratoire  
 La Collégiale Saint Pierre les Liens  
 La Maison des Familles  
 Paroisse St. Ferdinand

## GERMANY

Dom Forum  
 Epiphania Kirche  
 Evang. Luther Gemeindehaus  
 Evangelische Kirche  
 Evangelisches Predigerseminar  
 Evangelische Gesamtkirchengemeinde Ingolstadt  
 Evangelische Kirchengemeinde Bochum  
 Französische Friedrichstadtkirche  
 Gemeindehaus Hauptkirche St. Nikolai  
 Glockenberg  
 Johanneskirche Troisdorf  
 Jugendkirche Hannover  
 Katholische Kirchengemeinde St. Martini  
 Kloster Zangenberg  
 Liebfrauenkirche Bremen  
 Lukaskirche Gevelsberg  
 Pfarrzentrum Hard  
 Pfarrzentrum Heilig Blut  
 St. Martini Kirche  
 St. Nikolaj Kirche  
 St. Petri-Kapelle

## ITALY

Centro Parrocchiale

## THE NETHERLANDS

Bankras Kerk  
 Crematorium Haarlem  
 Cunerakerk  
 De Grote Kerk  
 De Nieuwe Kerk  
 Gemeente Lochem  
 Liberaal Joodse Gemeente Amsterdam  
 Nieuwe Kerk  
 Protestantse Gemeente Haarlem

## SPAIN

Arzobispado de Granada  
 Iglesia de Santo Tomás de Canterbury

## SWEDEN

Raege Kirke

## SWITZERLAND

Eglise de Gollion  
 Zeka in Baden

## UK

Bristol Cathedral  
 Canterbury Cathedral  
 Chelmsford Cathedral  
 Christ Church Cathedral School  
 Ely Cathedral  
 Exeter Cathedral  
 Glasgow University Chapel  
 Gloucester Cathedral  
 Leeds Cathedral  
 Leicester Cathedral  
 Liverpool Cathedral  
 Manchester Cathedral  
 Methodist Church  
 Newport Cathedral  
 North Western Reform Synagogue  
 Norwich Cathedral  
 Portsmouth Cathedral  
 Rochester Cathedral  
 Salisbury Cathedral  
 St. Aldate's Church  
 St. Andrew' and St. George's West Church  
 St. Clements Church  
 St. David's Cathedral  
 St. Georges Chapel - Great Yarmouth  
 St. Giles Cathedral  
 St. Helen's Bishopsgate  
 St. Helen's Church  
 St. Hughes  
 St. Mary le More Church  
 St. Mary's Church Witney  
 St. Paul's and St. George's Church  
 St. Paul's Cathedral  
 St. Stephens Church  
 Wakefield Cathedral  
 Wanstead United Reform Church  
 West Leigh Baptist Church  
 Worcester Cathedral

## USA

Cathedral Church of St. Paul's  
 First Unitarian Church of St. Louis  
 Philadelphia Episcopal Cathedral  
 The Parish of All Saints  
 Unitarian Universalist Fellowship  
 of Central Oregon  
 Word of Faith

and many more...

# Moving Design

We believe in the sense of movement at HOWE; the idea that what we do is not only moving the levels of craftsmanship or the confinements within design but also the people who use it every day. This is why all chairs and tables from HOWE offer impeccable functionality. You can fold them. You can stack them. You can roll them any way that you want, optimising the spaces in which we work, think, study and communicate. Just as you can feel comfort in them; the look, the originality, the way form follows function to the very last detail.

Time and time again.

We are HOWE and we believe in moving design.

Since 1928.

For further information please contact us:

EU/EMEA:

[cs@howe.com](mailto:cs@howe.com)

+45 63 41 64 00

USA:

[csus@howe.com](mailto:csus@howe.com)

616-419-2226

**HOWE**  
MOVING DESIGN  
SINCE 1928